

**Part Number: PT929-47190**

**Kit Contents**

Item #	Quantity Reqd.	Description
1	1	Applique, RR Bumper
2		

**Hardware Bag Contents**

Item #	Quantity Reqd.	Description
1		
2		

**Additional Items Required For Installation**

Item #	Quantity Reqd.	Description
1		
2		

**Conflicts**

None
------

**Recommended Tools**

<b>Personal &amp; Vehicle Protection</b>	<b>Notes</b>												
Protective Blanket													
<b>Special Tools</b>	<b>Notes</b>												
Squeegee	4" (3M™ Gold) or 4" (3M™ Silver)												
Low Friction Sleeve	3M SA-1 (Optional)												
Surface Thermometer	Infrared Non-contact												
Heat Gun	Master Heat Gun HG-301A or equivalent												
<b>Installation Tools</b>	<b>Notes</b>												
Lint Free Cloth													
Spray Bottle	For wetting agent												
<b>Special Chemicals</b>	<b>Notes</b>												
Cleaner	VDC approved cleaner and cleaning method												
Wetting Agent Note: Solution depends on the <u>part and the vehicle surface temperature</u> . Not only on ambient temperature.	Johnson's Baby Shampoo mixed PER LITER of water: <table border="1" style="margin-left: 20px;"> <thead> <tr> <th>Temp</th> <th>Shampoo</th> </tr> </thead> <tbody> <tr> <td>65° F</td> <td>.5 mL</td> </tr> <tr> <td>70° F</td> <td>.75 mL</td> </tr> <tr> <td>80° F</td> <td>1 mL</td> </tr> <tr> <td>90° F</td> <td>1.5 mL</td> </tr> <tr> <td>100° F</td> <td>2 mL</td> </tr> </tbody> </table>	Temp	Shampoo	65° F	.5 mL	70° F	.75 mL	80° F	1 mL	90° F	1.5 mL	100° F	2 mL
Temp	Shampoo												
65° F	.5 mL												
70° F	.75 mL												
80° F	1 mL												
90° F	1.5 mL												
100° F	2 mL												

**General Applicability**

MY19 and newer Prius models
-----------------------------

**Recommended Sequence of Application**







Item #	Accessory
1	
2	

\*Mandatory

**Vehicle Service Parts** (may be required for reassembly)

Item #	Quantity Reqd.	Description
1		
2		

**Legend**

	<b>STOP:</b> Damage to the vehicle may occur. Do not proceed until process has been complied with.
	<b>OPERATOR SAFETY:</b> Use caution to avoid risk of injury.
	<b>CAUTION:</b> A process that must be carefully observed in order to reduce the risk of damage to the accessory/vehicle and to ensure a quality installation.
	<b>TOOLS &amp; EQUIPMENT:</b> Used in Figures calls out the specific tools and equipment recommended for this process.
	<b>REVISION MARK:</b> This mark highlights a change in installation with respect to previous issue.
	<b>SAFETY TORQUE:</b> This mark indicates that torque is related to safety.

## Procedure

Care must be taken when installing this accessory to ensure damage does not occur to the vehicle. The installation of this accessory should follow approved guidelines to ensure a quality installation.



These guidelines can be found in the "Accessory Installation Practices" document.

This document covers such items as:-

- Vehicle Protection (use of covers and blankets, cleaning chemicals, etc.).
- Safety (eye protection, rechecking torque procedure, etc.).
- Vehicle Disassembly/Reassembly (panel removal, part storage, etc.).
- Electrical Component Disassembly/Reassembly (battery disconnection, connector removal, etc.).

Please see your Toyota dealer for a copy of this document.

### 1. Prepare the Vehicle.

-  (a) The part and vehicle surface temperature must be maintained between 65°F and 90°F (18°C and 32°C) for optimum installation. Store parts flat at room temperature in a clean dry place.
- (b) Place a protective blanket in the trunk area to protect it from overspray of the wetting agent.
-  (c) Clean the entire application surface to remove grease and wax. Clean the entire area with a VDC approved cleaner and cleaning method.
- (d) Wipe the cleaned surface with a clean, dry, lint-free cloth.

### 2. Install the Rear Bumper Applique.

-  (a) Place the part face down on a clean flat surface. Remove the entire liner (Fig. 2-1).

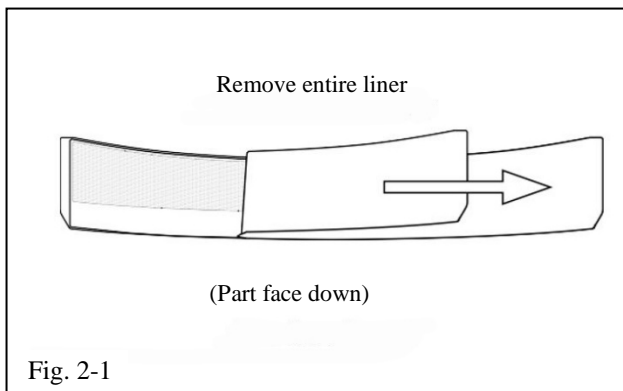

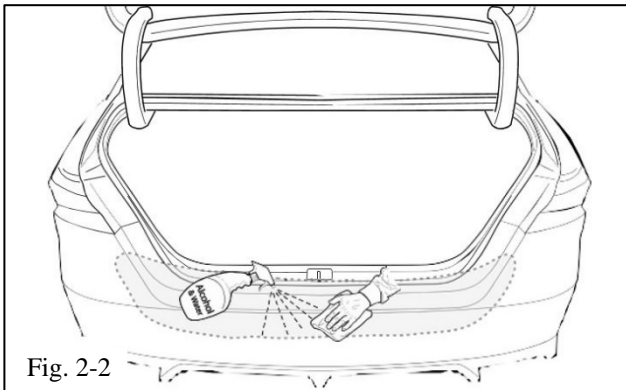

Fig. 2-2

- (b) Mist the part and bumper with wetting agent (Fig. 2-2).

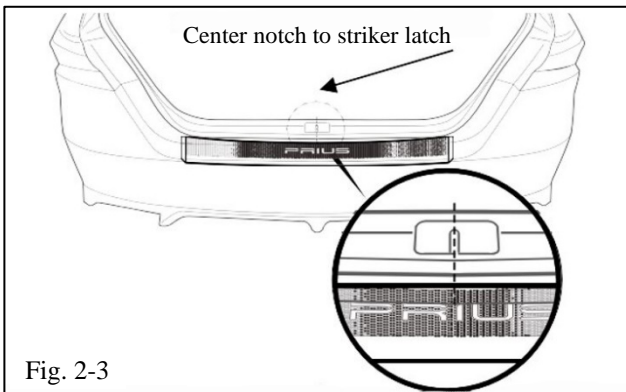

Fig. 2-3

- (c) Align the center notch directly below the striker latch opening and the leading edge of the pre-mask along the vertical surface of the bumper (Fig. 2-3).

**⚠ NOTE:** Make sure not to roll onto the vertical surface. Do not smooth the part with your hands.

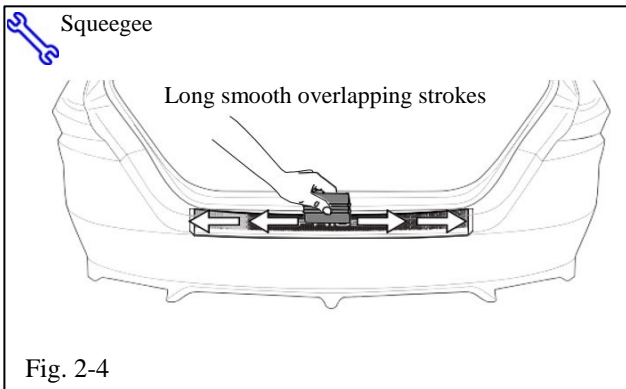

Fig. 2-4

- (d) Using long smooth overlapping strokes squeegee from the center outwards of the horizontal surface (Fig. 2-4).

**⚠ NOTE:** Do not use excessive force as it may cause creasing of the applique. If the part moves as you begin to squeegee, either excessive force is being used or mixture contains too much soap.

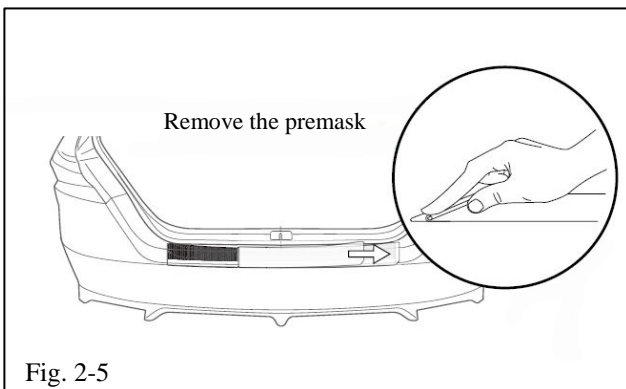
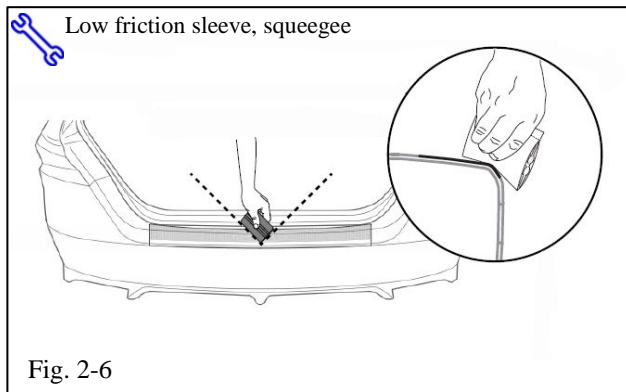
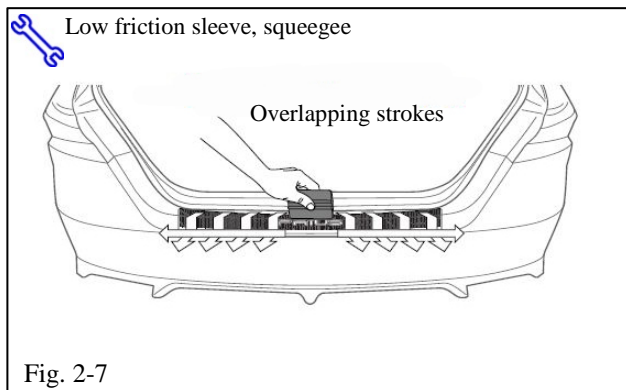

Fig. 2-5

- (e) Carefully remove the pre-mask paper by rolling it back 180° against itself prior to squeegeeing the angled surface of the bumper (Fig. 2-5).



- (f) While holding the squeegee at 45° angle make smooth continuous strokes from the center outwards on the angled surface (Fig. 2-6 and Fig. 2-7).
- (g) Dry off the vehicle with clean lint free cloth.



**TOYOTA                      PRIUS                      2019 -                      REAR BUMPER APPLIQUE**  
Checklist - these points **MUST** be checked to ensure a quality installation.

<u>Check:</u>	<u>Look For:</u>
<p><u>Accessory Function Checks</u></p> <p><input type="checkbox"/> Proper adhesion – Visual</p> <p><input type="checkbox"/> Proper adhesion – Physical</p> <p><input type="checkbox"/> Proper alignment – Cross-Car</p>	<p>Look for bubbles, loose and lifting edges.</p> <p>With light pressure, rub a hand over the top of the part and if a crackling sound occurs, re-squeegee. If bubbles cannot be worked out to the nearest edge, replace the part.</p> <p>The part must be centered within the bumper +/-3 mm.</p>
<p><u>Vehicle Appearance Check</u></p> <p><input type="checkbox"/> After accessory installation and removal of protective cover(s), perform a visual inspection.</p>	<p>Ensure no damage (including scuffs and scratches) was caused during the installation process.</p> <p>(For PPO installations, refer to TMS Accessory Quality Shipping Standard.)</p>